

# NeedWant Narrow Shelving

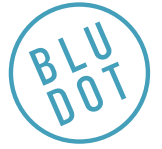

DESIGNED IN 2019

ASSEMBLY NOTES | REV 00

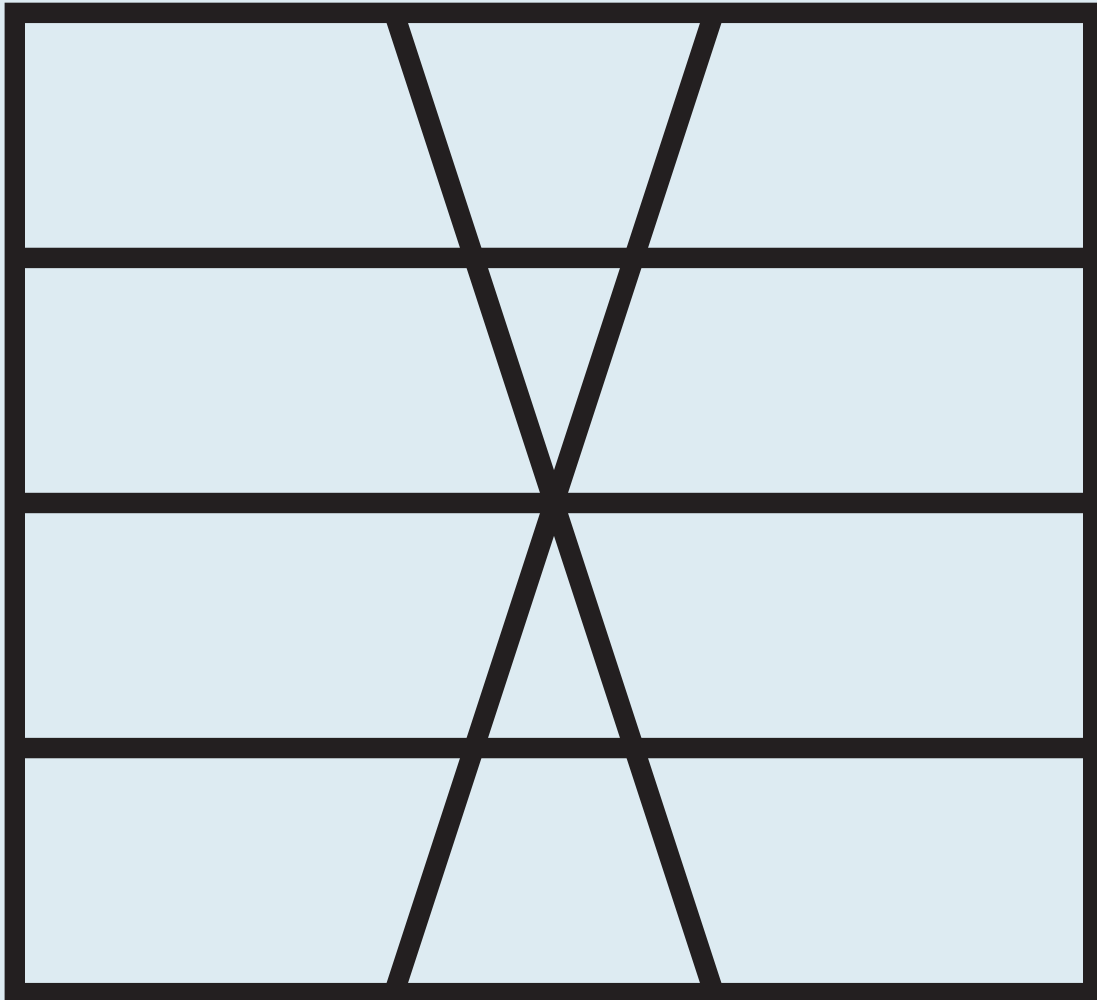

## HAVE IT ALL?

Can things really make us happy? Well, there is no better way to test the theory than with this powder coated steel architectural wonder.

## NEED A HAND?

Contact us at [service@bludot.com](mailto:service@bludot.com) or **844.425.8368** for assistance.

# Parts & Hardware

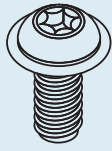

QTY 20

PT. 1107

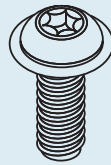

QTY 10

PT. 1108

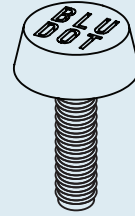

QTY 6

PT. 4022

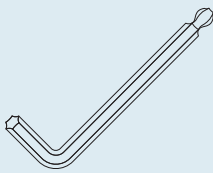

QTY 1

PT. 9032

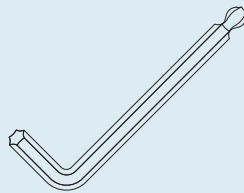

QTY 1

PT. 9016

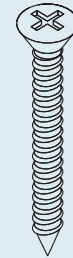

QTY 4

PT. 1218

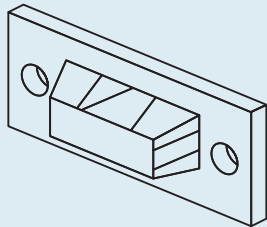

QTY 2

PT. 8041



QTY 4

PT. 8054

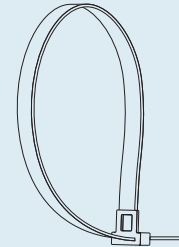

QTY 2

PT. 8042

# Parts & Hardware

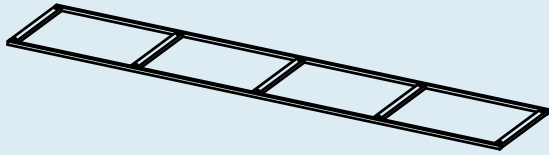

QTY \_\_\_\_\_ 2

Side Frame



QTY \_\_\_\_\_ 1

Shelf 5



QTY \_\_\_\_\_ 1

Shelf 4

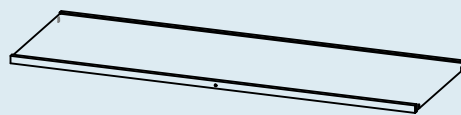

QTY \_\_\_\_\_ 1

Shelf 3

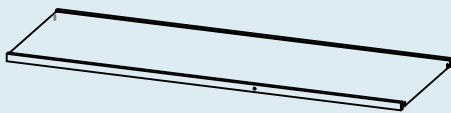

QTY \_\_\_\_\_ 1

Shelf 2



QTY \_\_\_\_\_ 1

Shelf 1

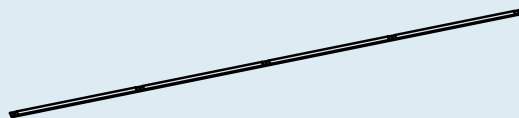

QTY \_\_\_\_\_ 2

Support Rail

# Step 01

START ASSEMBLY.

Start assembly by threading bolt onto side frame by hand. Do not fully tighten.

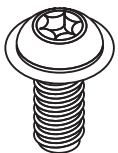
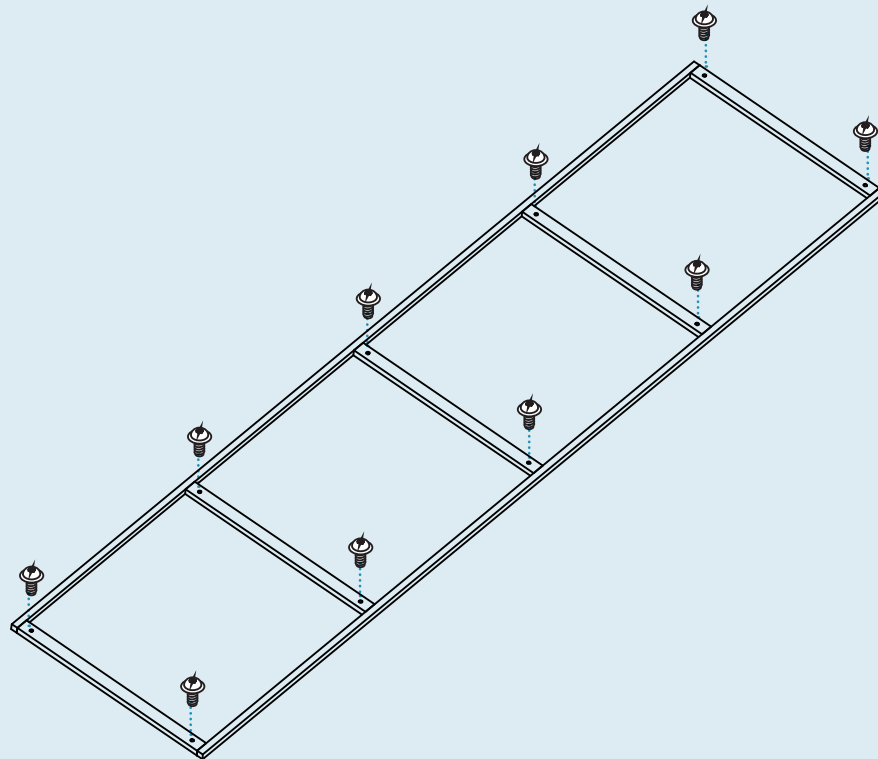

PT. 1107 x 10

# Step 02

## INSTALL SHELF 1.

Align shelf 1 brackets with bolts on side frame. Slide shelf 1 down to engage with side frame bolts. Use the provided allen wrench to tighten bolts.

Note: The front of the shelves contain identification labels to help with assembly. The shelf labels should only be removed after the product is fully assembled.

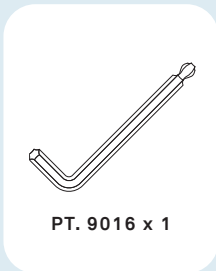
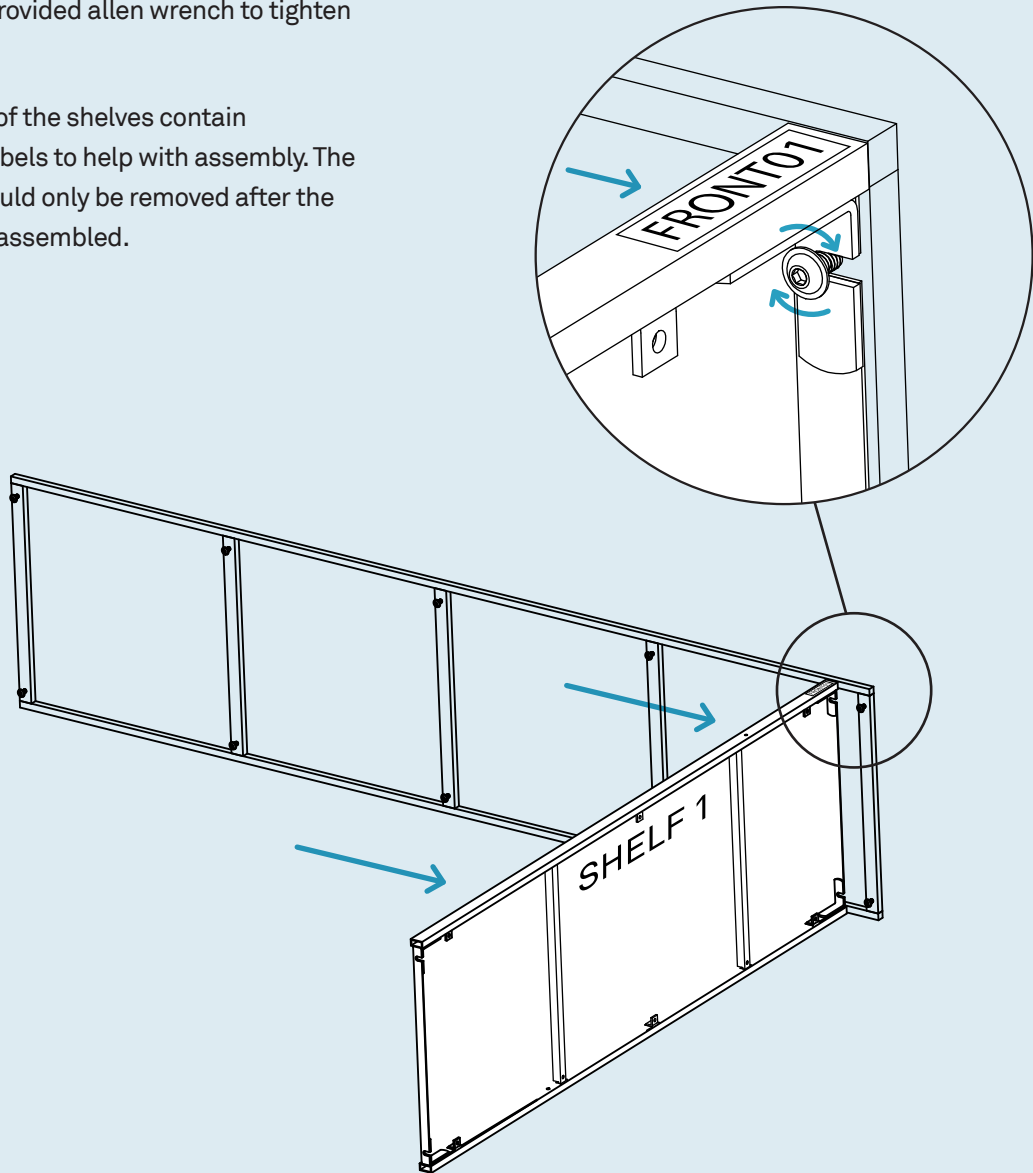

## Step 03

### ATTACH REMAINING SHELVES.

Repeat Step 02 assembly for the remaining shelves. Ensure that the shelves are in the correct location and orientation as shown below.

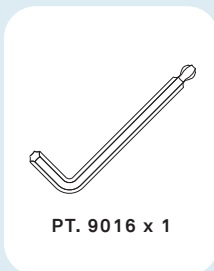
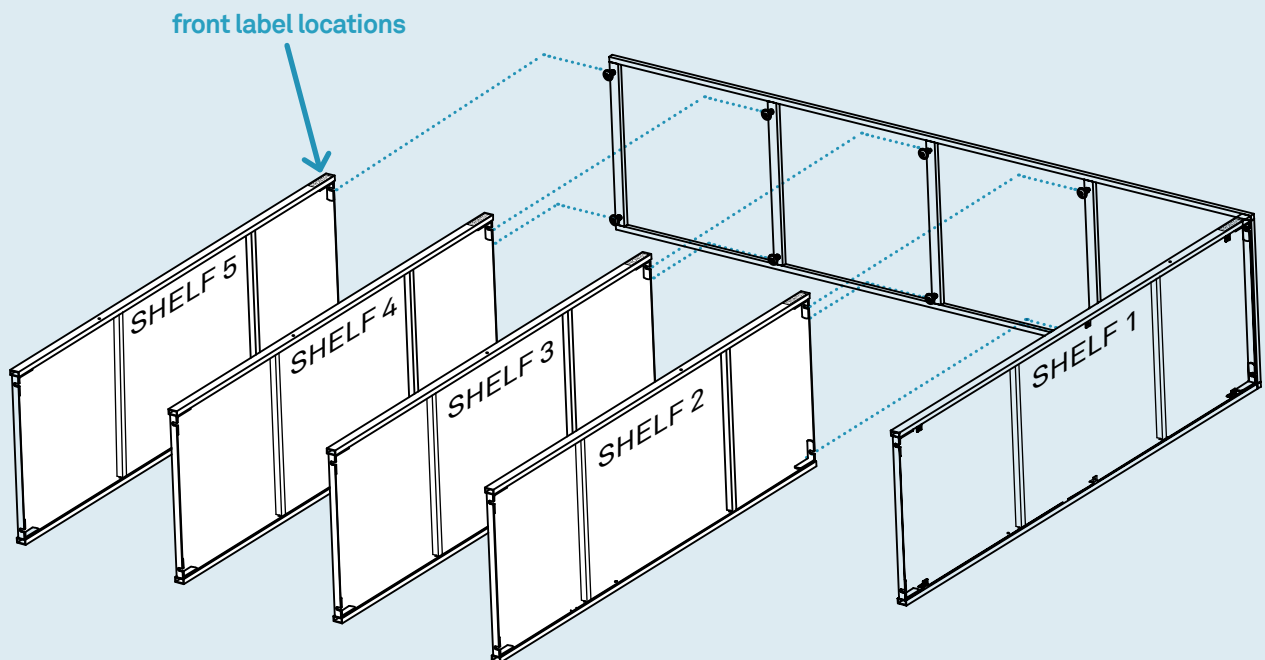

# Step 04

ATTACH REMAINING SIDE FRAME.

Use the provided hardware to attach the remaining side frame.

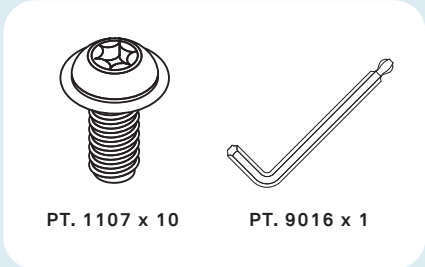
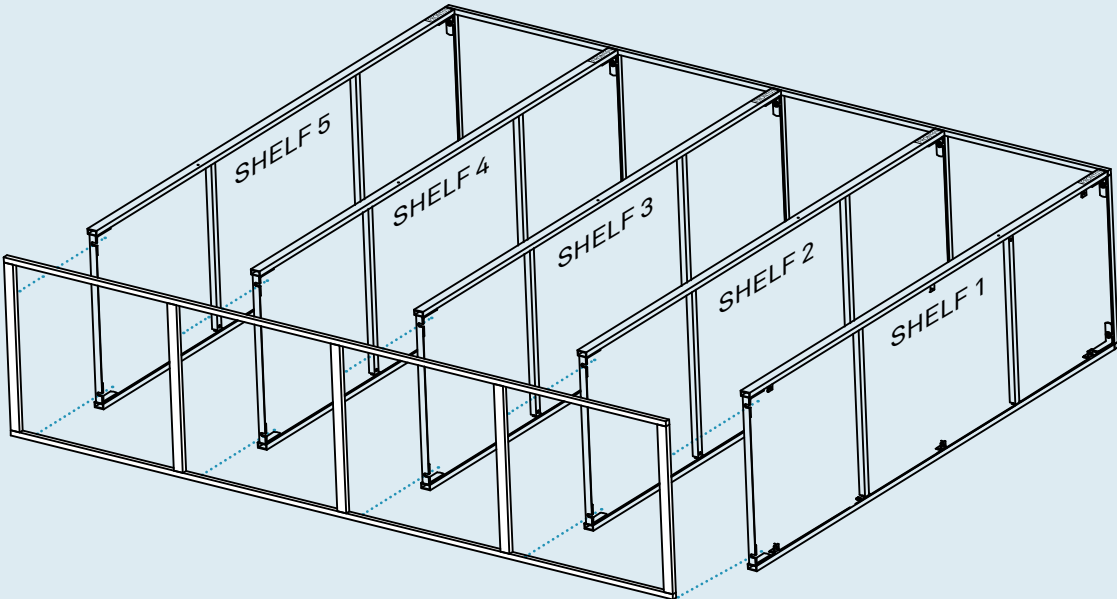

# Step 05

## ATTACH SUPPORT RAIL.

Align support rail notches with shelf rails to match the below image. Attach the support rail using the provided hardware.

Once the support rail is attached, thread provided adjustable feet to bottom shelf as shown.

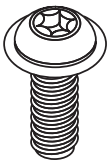
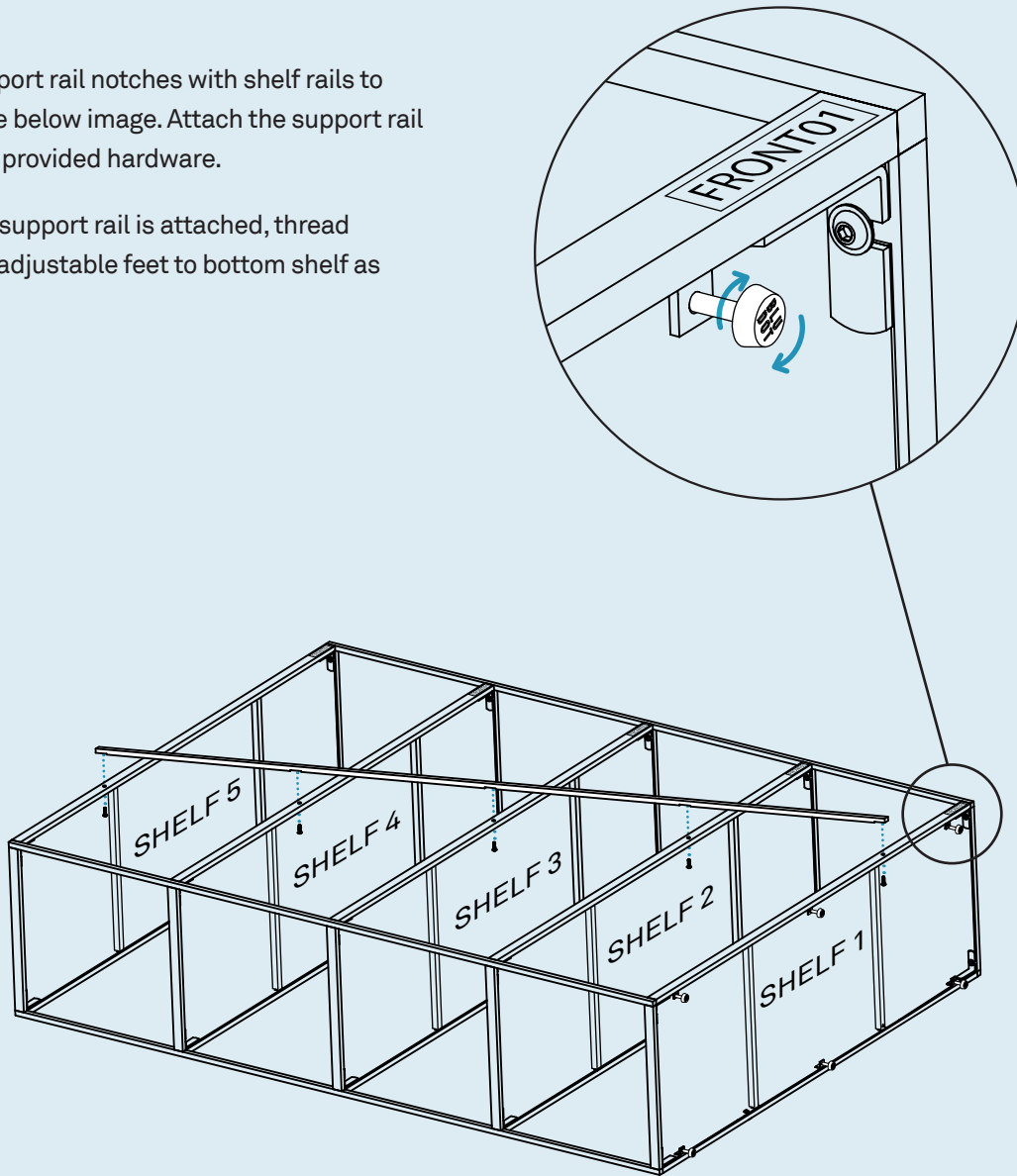

PT. 1108 x 5

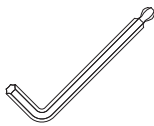

PT. 9032 x 1

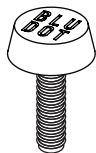

PT. 4022 x 6



# Step 06

## ATTACH REMAINING SUPPORT RAIL.

Use packaging materials to raise shelving off floor. Align support rail notches with shelf rails to match the below image. Attach the support rail using the provided hardware.

Ensure all bolts are tightened. Have a second person help lift and bring the shelf upright.

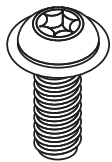
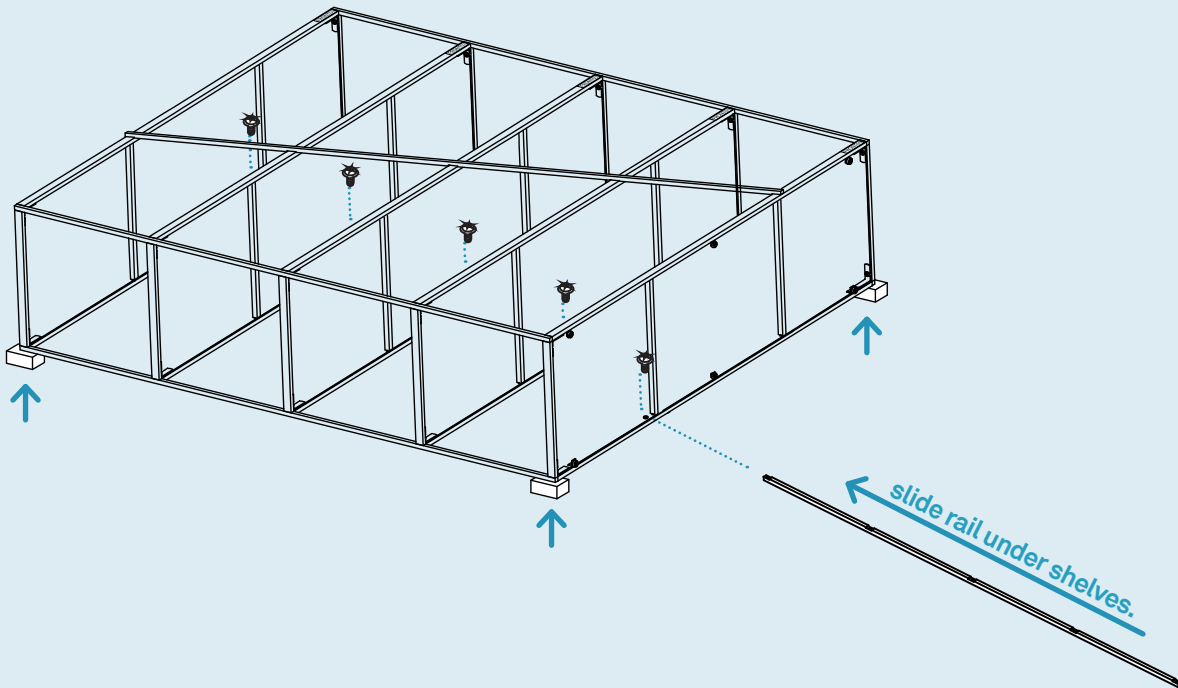

PT. 1108 x 5

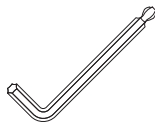

PT. 9032 x 1

# Step 07

## INSTALL WALL BRACKETS.

Wall anchors and fasteners are included for installation into drywall. Please consult your local hardware professional to determine the hardware best suited for your wall type.

If the mounting locations are not positioned on a stud, drill **15/64"** holes in the marked locations. Press wall anchors into drilled holes.

If the mounting locations are positioned on a stud, this step of installing wall anchors may be skipped. Instead, drill **7/64"** pilot holes in the marked locations.

Attach the wall brackets to the wall using the included fasteners as shown.

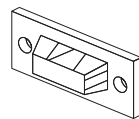
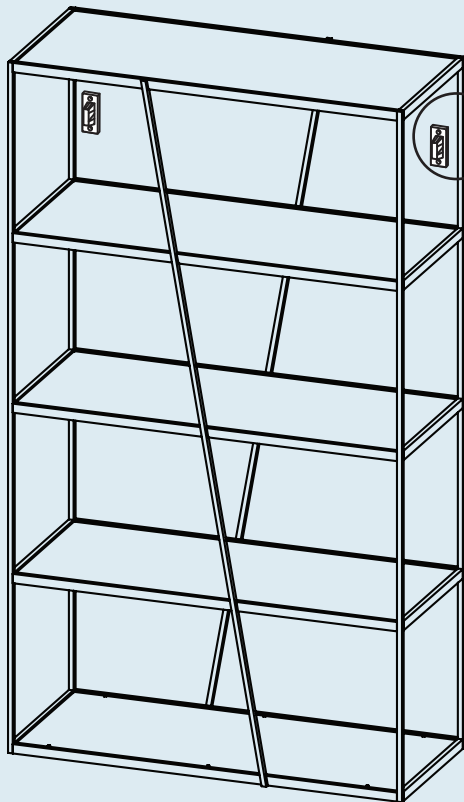
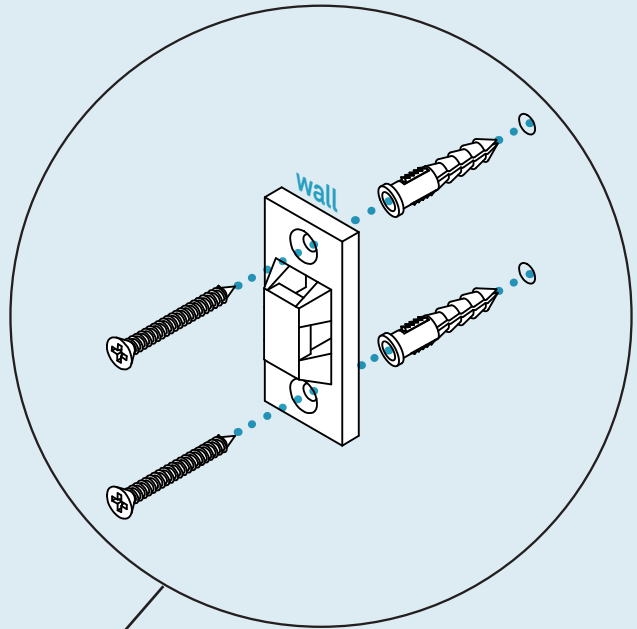

PT. 8041 x 2



PT. 8054 x 4

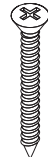

PT. 1218 x 4

# Step 08

## SECURE THE SHELF.

Install and tighten the straps prior to using the product.

Adjust the feet to ensure the shelf is level prior to using the product.

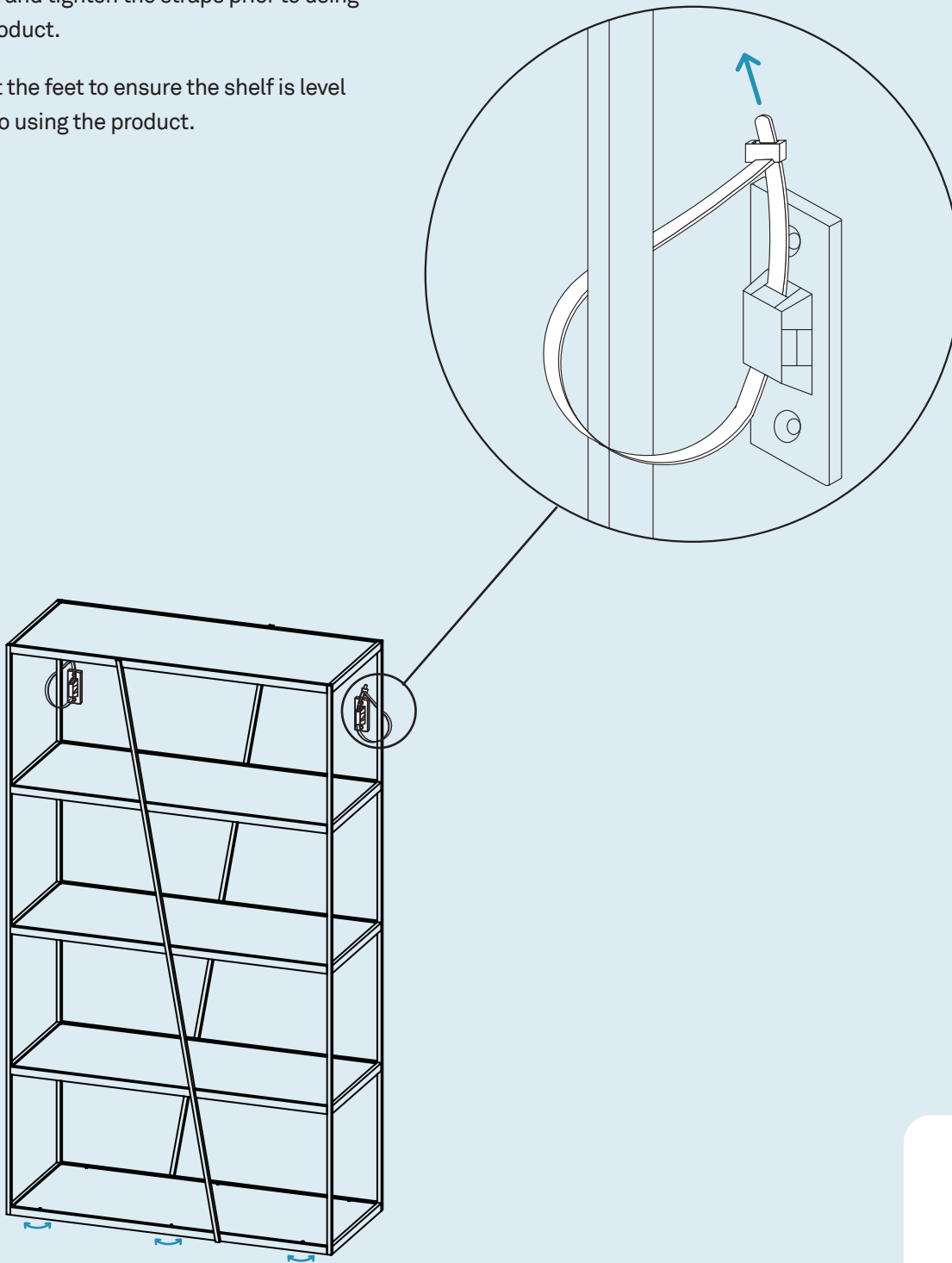

PT. 8042 x 2

## Additional Information

### CLEAN

Clean with a slightly damp, soft cloth. To remove dirt and fingerprints, use a quality cleaner formulated for painted metal furniture. Wipe completely dry with a soft cloth.

